

# W Collection

## WMP9170BLAUS

### BUILT-IN 90CM MULTI-FUNCTION OVEN



## FEATURES & BENEFITS



#### FLEXI CLEAN

With the options of Pyrolytic or Smart Clean/Hydrolytic. Pyrolytic technology uses a high-temperature cycle to burn food residues into ashes, which can then be easily wiped away with a sponge. This ensures spotless cleaning with minimal effort. Smart Clean enables the steam to release during special low-temperature cleaning cycle allows dirt and food residues to be removed with ease. With SmartClean, the oven can be cleaned quickly and environmentally.



#### MEAT PROBE

The meat probe monitors the temperature of the food to ensure complete temperature control inside and out.



#### XXL CAVITY

All the space you need. The XXL cavity in your oven has a capacity of 133 Litres with 5 different shelf positions available.



#### AIR FRY FUNCTION

The Air Fryer function is a cooking mode that uses a powerful fan to rapidly circulate hot air throughout the oven cavity, delivering crispy, fried-like results with minimal oil.



#### WARRANTY

Guarantees peace of mind and value for money knowing that any product fault or defect is covered by full replacement parts and/or a service call to ensure the product works as described.

## TECHNICAL SPECIFICATIONS

COLOUR/FINISH	Black Glass
DISPLAY	LED Digital
CONTROL	Touch
DOOR / HANDLE DESIGN	Quadruple Glass Door with Black Handle
CAVITY TYPE	Enamelled
CAPACITY	133 litres
COOKING SHELVES	5 shelves
WEIGHT	53kg
PRODUCT DIMENSION	W 894mm x H 595mm x D 575mm
CUT OUT DIMENSION	W 896-900 mm x H 597-600mm x D 580-600mm
HEATING METHODS	Conventional, Convect Bake, Forced Air, Pizza, Defrost, Grill, Maxi Grill, Turbo Grill, Multi-Cook, Air Fry, Delicate Cook, Eco Forced Air
HEATING TEMPERATURE	30 deg to 260 deg
FEATURES	Delay Start, Favourite, Child Lock
CLEANING	Pyrolytic Cleaning & Smart Clean (Hydrolytic Cleaning)
ACCESSORIES	Wire Shelf x 1, Baking Tray Set x 1, Air Fry Basket Set x 1, Telescopic Rails x 1 pair, Wired Meat Probe x 1
MAX. TOTAL POWER	3000-3600 W
VOLTAGE	220-240 V
FREQUENCY	50
LENGTH OF ELECTRICAL CORD	110 cm, no plug
PACKAGING DIMENSIONS	W 942mm x H 665.5 mm x D 658mm
GROSS WEIGHT	57.5 kg
NET WEIGHT	53 kg
PLACE OF MANUFACTURE	Asia

DISTRIBUTED BY ARISIT PTY LTD

40-50 Mark Anthony Drive, Dandenong South VIC 3175  
Ph: 1300 762 219 Fax: 03 9768 0838 Website: www.arisit.com

03/2025

## INSTALLATION GUIDE

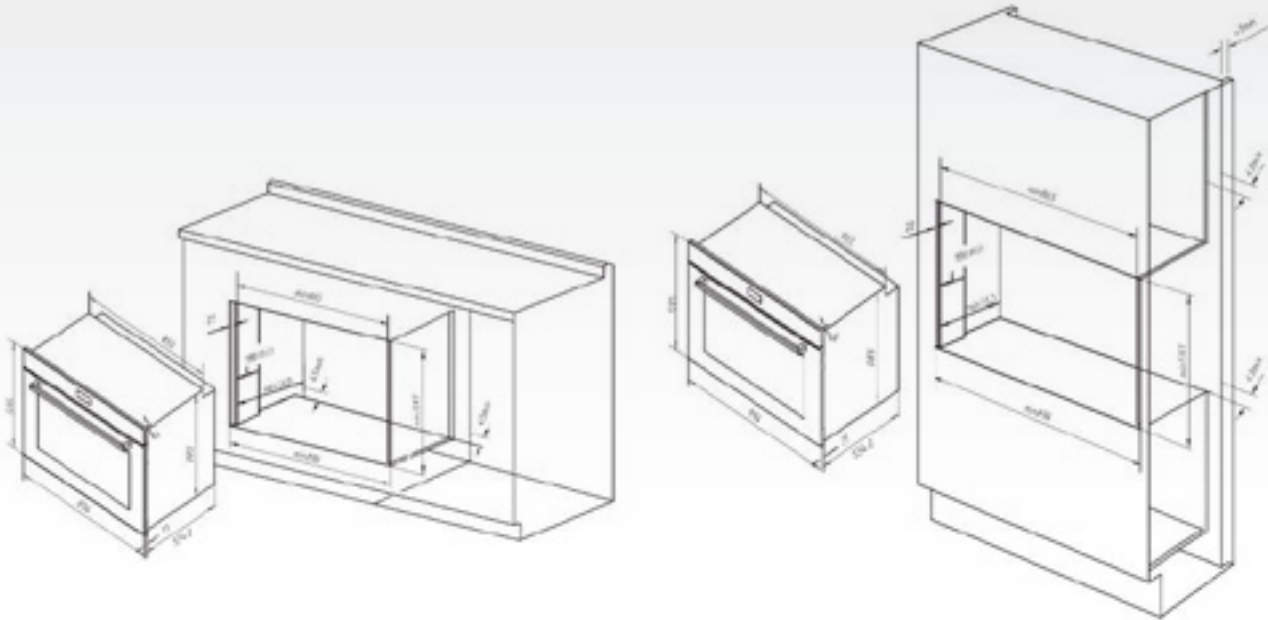

## CONTROL PANEL



1. **ON/OFF BUTTON**  
For switching the oven on and off for stopping an active function.
2. **FUNCTION BUTTON**  
For access to the functions and menus.
3. **TEMPERATURE BUTTON**  
For accessing the temperature you require when activating functions.
4. **DISPLAY**
5. **TIME BUTTON**  
For accessing the cooking time settings, delayed start and timer.  
For displaying the time when the oven is off.
6. **FAST PREHEAT**  
For preheating the oven quickly.
7. **NAVIGATION BUTTONS**  
For increasing/decreasing the settings or values of a function.
8. **LIGHT BUTTON**  
With the oven switched on, press  to turn the oven compartment lamp on or off.