

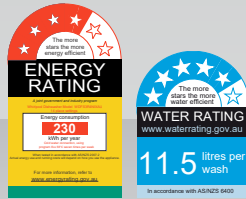

W Collection

WDFS3R4NIXAU 60CM 14 PLACE SETTING FREE-STANDING DISHWASHER



FEATURES & BENEFITS



6TH SENSE TECHNOLOGY

With 6th sense technology, it automatically senses how dirty the dishes are and adapts the cycle time and water pressure accordingly. It ensures to provide the perfect performance with water, energy & time saving.



HALF LOAD

If there are not many dishes to be washed, a half loading may be used in order to save water, electricity and detergent.



SANITIZATION

Thanks to Sanitization option, it could eliminate 99.999% bacteria and provide more HYGIENE experience



NATURAL DRY

The automatic door opening at the end of the program ensures better and more natural drying. This system guarantees higher energy efficiency and better drying results.



FLEXIBLE UPPER RACK

The height of the upper rack can be adjusted according to your needs: high position to place bulky crockery in the lower basket and low position to make the most of the tip-up supports by creating more space upwards and avoid collision



MAXI-SPACE

Thanks to the Maxi-Space, the dishwasher provides you with a larger internal usable space that offers you greater ease and versatility to fit all your soiled dishes within.



5 YEAR WARRANTY

Guarantees peace of mind and value for money knowing that any product fault or defect is covered by full replacement parts and/or a service call to ensure the product works as described.

TECHNICAL SPECIFICATIONS

COLOUR / FINISH	Stainless Steel Color
DISPLAY	LED Display
CONTROL	Touch UI
DOOR / HANDLE DESIGN	Square
CAPACITY	14 place settings
NET WEIGHT	50kg
PRODUCT DIMENSION	W 600mm x H 850mm x D 590mm
PROGRAMMES	Eco, Auto Intensive, Auto Mixed, Auto Fast, Crystals, Rapid, Prewash, Selfclean
FEATURES	6th Sense, Half Load, Sanitization, Natural Dry, Removable cutlery rack, Removable upper rack with double cup shelves and rubber mat for glass protection, Removable Lower rack, Dual Inverter, Maxi-Space.
NOISE	45 dBA
WATER CONSUMPTION	11.5 liters
WATER RATING	5.0 stars rating
ENERGY CONSUMPTION	230 kwh/year
ENERGY RATING	4.0 stars rating
VOLTAGE	220 - 240V
CURRENT	10 amp
PLUG TYPE	Australian
LENGTH OF HOSE	Inlet: 155cm Outlet: 150 cm
LENGTH OF ELECTRIC CORD	130cm
PACKAGING DIMENSIONS	W 625mm x H 910mm x D 675mm
GROSS WEIGHT	53kg
PLACE OF MANUFACTURE	Made in China

DISTRIBUTED BY ARISIT PTY LTD

40-50 Mark Anthony Drive, Dandenong South VIC 3175
Ph: 1300 762 219 Fax: 03 9768 0838 Website: www.arisit.com

INSTALLATION GUIDE

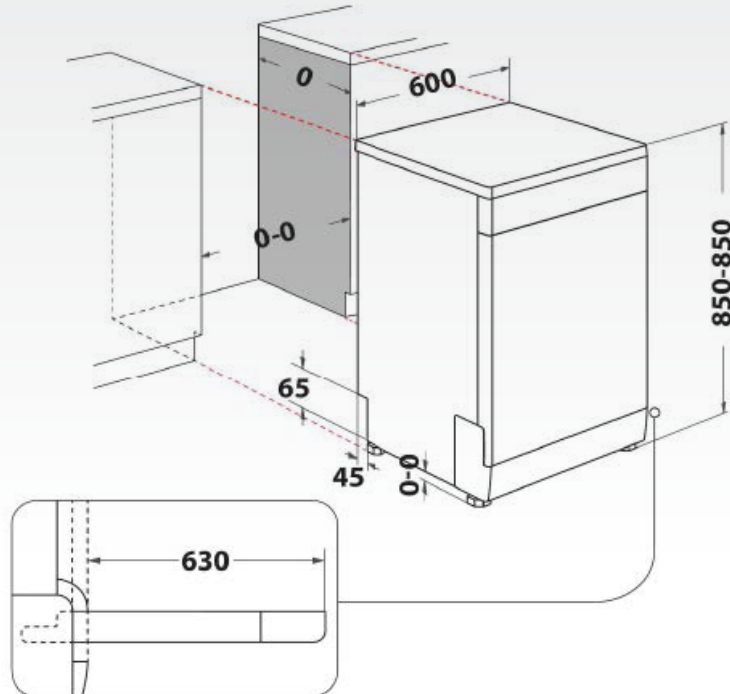

CONTROL PANEL

CONTROL PANEL



- | | |
|---|--|
| <ol style="list-style-type: none"> 1. ON-OFF/Reset button with indicator light 2. Eco program button with indicator light 3. Auto Intensive program button with indicator light 4. Auto Mixed program button with indicator light 5. Auto Fast program button with indicator light 6. Rapid program button with indicator light 7. Crystals program button with indicator light 8. Prewash program button with indicator light 9. Salt reservoir empty indicator light 10. Rinse Aid reservoir empty indicator light 11. Display | <ol style="list-style-type: none"> 12. Program number and remaining time indicator 13. Closed water tap indicator light 14. DESCALE indicator light 15. Power Clean® option button with indicator light 16. Half Load option button with indicator light/ Settings - 3 sec. press 17. Extra Dry option button with indicator light 18. Silent option button with indicator light/ Key lock - 3 sec. press 19. Sani Rinse option button with indicator light 20. Self-Clean program button with indicator light 21. Delay option button with indicator light 22. START/Pause button with indicator light |
|---|--|