



# W Collection

## W70M44S1PBLAUS

### BUILT-IN SELF CLEANING ELECTRIC OVEN



## FEATURES & BENEFITS



### 6TH SENSE

No more guesswork. Simply pick your recipes, and let 6th SENSE cook them to perfection, every time. Up to 40 cooking combinations organized to fit your lifestyle and diet, for a full assisted cooking experience.



### READY2COOK

No pre-heating required. The Ready2Cook function uses a powerful convection system to quickly reach the right temperature, and completely eliminate the need for pre-heating.



### FORCED AIR

Seal in the taste. Thanks to the Forced Air technology, preheated air is circulated inside your Oven using an innovative convection system, giving you moist, juicy cooking results.



### SOFT CLOSING

Slow-motion closing. Thanks to slow-closing hinges, the oven door shuts effortlessly, with a soft and silent motion.



### WARRANTY

5 Year warranty on parts and labour.

## TECHNICAL SPECIFICATIONS

COLOUR/FINISH	Black
DISPLAY	LED Digital
CONTROL	Electrical
DOOR / HANDLE DESIGN	Full Glass Door with Black Handle
CAVITY TYPE	Enamelled
CAPACITY	73 litres
CLEANING	Pyrolytic
PRODUCT DIMENSION	W 595mm x H 595mm x D 564mm
14 FUNCTIONS	6th SENSE Cook (40 Combinations), Cook 4, Forced Air, Convection Bake, Turbo Grill, Frozen Bake, Maxi Cooking, Rising, Defrosting, Keep Warm, Eco Forced Air, Conventional, Grill, Fast Preheat
MAX. TOTAL POWER	3300W
VOLTAGE	220-240 V
CURRENT	16 amp
ELECTRICAL CORD	90cm
NET WEIGHT	40.5kg
WARRANTY	Five Year Parts and Labour

## INSTALLATION GUIDE

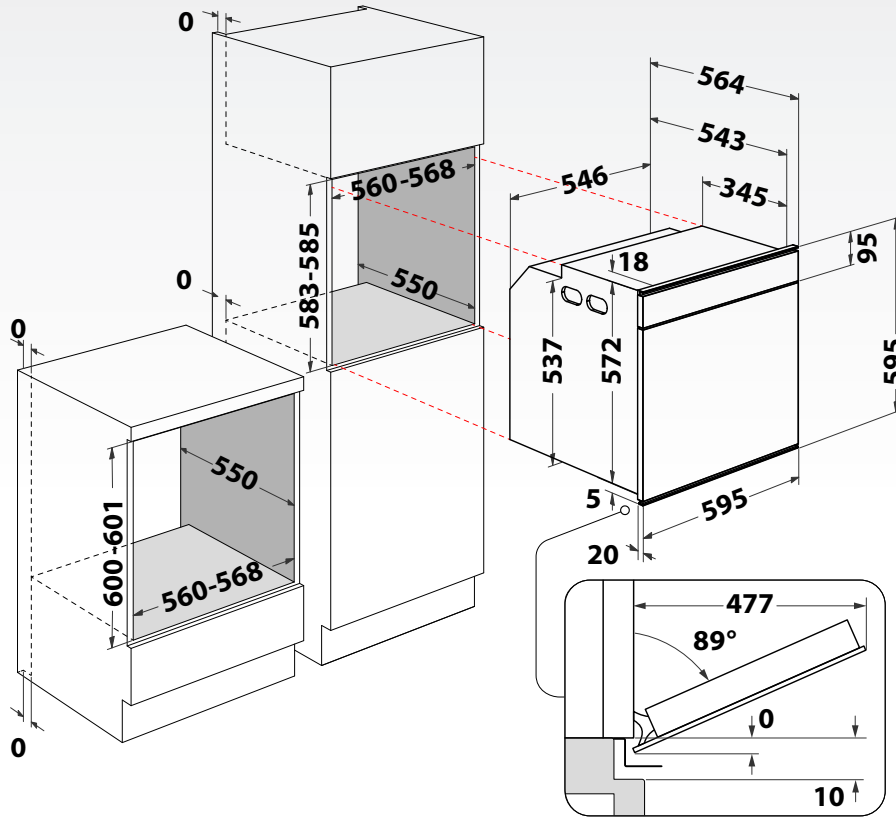

## CONTROL PANEL

