

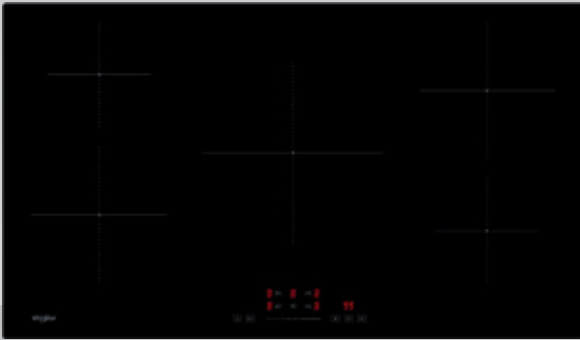

IWSH9051CAUS

90CM 5 ZONE BUILT-IN INDUCTION COOKTOP



FEATURES & BENEFITS



INDUCTION TECHNOLOGY

Induction technology heats the pan, not the hob, reducing energy dispersion as well as achieving faster and energy-efficient cooking.



BOOSTER

Thanks to the Booster function which the cooking zones of the hob are equipped with, boiling times are significantly reduced.



STOP & GO

Suspend the cooking process if you're interrupted then re-start again at the same temperature in an instant with the Stop & Go function.



BLACK CERAMIC GLASS

A completely smooth cooking surface makes the cooktop extremely easy to clean with just a wipe.



CHILD LOCK

Featuring a Child Lock function to prevent toddlers and children from accidentally using the hob.



WARRANTY

Guarantees peace of mind and value for money knowing that any product fault or defect is covered by full replacement parts and/or a service call to ensure the product works as described.

TECHNICAL SPECIFICATIONS

TYPE	90cm Built-in Induction Hob
COOKING ZONES	5
COLOR / FINISH	Black Ceramic Glass
CONTROL	Slider Touch Control
LOCATION OF CONTROL PANEL	Front
PRODUCT NET WEIGHT	16kg
PRODUCT DIMENSION	W 900mm x H 60mm x D 520mm
CUT-OUT DIMENSION	W 880mm x D 500mm
FUNCTIONS	Booster, Stop & Go Function
FEATURES	Child Lock, Timer, Pan Detection, Residual Heat Indicator, Auto Shutdown, Over-heat Protection, Over-flow Protection
TOTAL POWER	10,200W
LEFT, FRONT ZONE	2,000W (Booster 3,000W)
LEFT, REAR ZONE	1,500W (Booster 2,000W)
CENTRAL ZONE	2,300W (Booster 3,000W)
RIGHT FRONT ZONE	1,500W (Booster 2,000W)
RIGHT REAR ZONE	2,000W (Booster 3,000W)
POWER SETTING	9 levels
ENERGY INPUT	Electric
POWER VOLTAGE	220-240V or 380-415V 3N~, 50-60Hz
LENGTH OF POWER CORD	110cm (without plug)
PACKAGING DIMENSION	W 1005mm x H 120mm x D 620mm
GROSS WEIGHT	19kg
EAN	4895120710887
COUNTRY OF ORIGIN	Asia
WARRANTY	5 Years

DISTRIBUTED BY ARISIT PTY LTD

40-50 Mark Anthony Drive, Dandenong South VIC 3175
Ph: 1300 762 219 Fax: 03 9768 0838 Website: www.arisit.com

INSTALLATION GUIDE

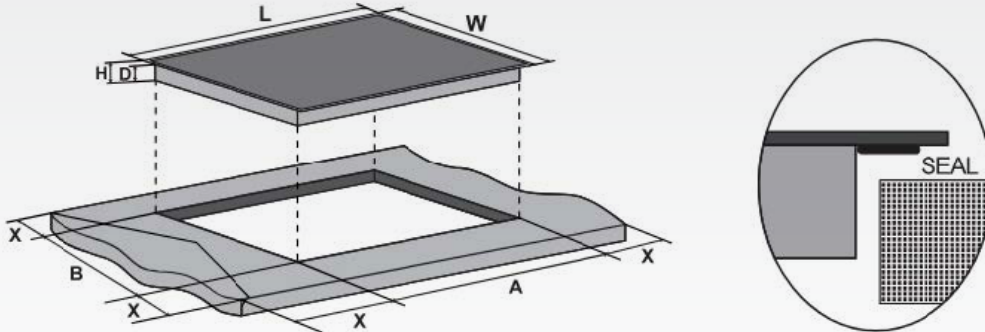

INDICATION	L	W	H	D	A	B	X
DIMENSION	900mm	520mm	60mm	52mm	880mm	500mm	50mm

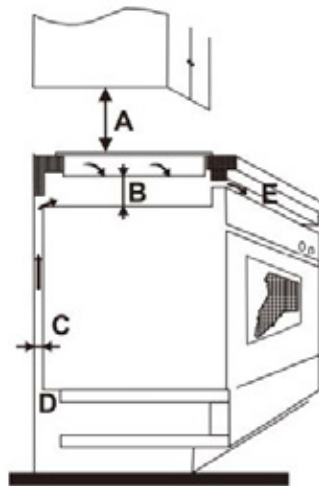

INDICATION	A	B	C	D	E
DIMENSION	760mm (min.)	50mm (min.)	20mm (min.)	20mm (Air inlet min.)	5mm (Air outlet min.)

CONTROL PANEL

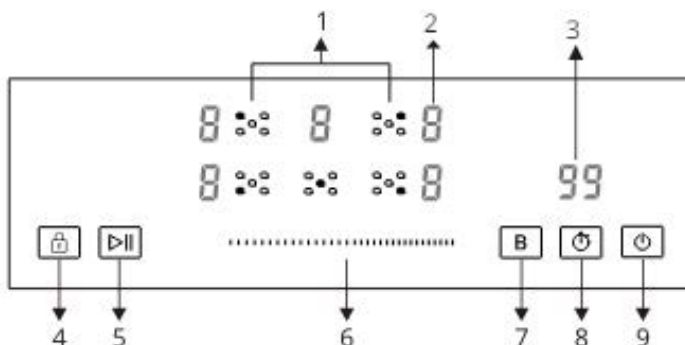

1. Cooking Zone selection button
2. Cooking level indicator
3. Timer indicator
4. Child Lock control button
5. Stop & Go control button
6. Scroll keypad
7. Booster function control button
8. Timer control button
9. ON/OFF button

DISTRIBUTED BY ARISIT PTY LTD

40-50 Mark Anthony Drive, Dandenong South VIC 3175
 Ph: 1300 762 219 Fax: 03 9768 0838 Website: www.arisit.com